



Technical Guideline for Connection of Indirect Solar PV Power Generation for Net Energy Metering



CONTENTS

Chapter	Page
1.0 Overview.....	2
2.0 Scope.....	4
3.0 Glossary	5
4.0 Description of Indirect Solar PV Power Generation.....	7
5.0 Connection Scheme	8
6.0 General Requirements	10
7.0 Penetration Limit	16
8.0 Protection Guidelines.....	17
9.0 Metering.....	21
10.0 Safety Requirements	22
11.0 Application Process	23
12.0 Testing & commissioning	26
13.0 Operation and Maintenance.....	27
14.0 Other Requirements	28
ATTACHMENT A : Smart Inverter Functions.....	29

1.0 Overview

1.1 Introduction : Connection of Solar PV generation system to the customers' internal system under the implementation of Net Energy Metering, requires a review of existing connection scheme and requirements.

The internal generation by the customers in aggregate would impact the Distribution system behaviour, especially when there is excess of generation from the customer. Due consideration of the impacts must be taken to mitigate the problem caused by the internal generation for example voltage rise, safety, power quality etc.

RE developers, service providers, operators and parties otherwise involved in the installation and commissioning of PV generation to the grid can utilise these guidelines for:

- a) Reference to issues related to grid connection of PV.
- b) Finding out the power quality requirements for PV interconnection with medium and low voltage distribution networks.
- c) Understanding the interconnecting requirements whether for small, intermediate or large PV systems.
- d) Finding out the methods available for interfacing of the PV generator to the grid system (connection schemes), including the compliance requirements for energy metering and SCADA.
- e) Understanding the practices to ensure the safety of the personnel and equipment involved in utility-connected PV operations.

1.2 Regulations : Paralleling indirect Solar PV power generation system to the grid shall be subjected to compliance to the prevailing electricity supply rules & regulations to ensure adherence to the standard practices, quality of supply and personal & public safety.

Regulating authority is Suruhanjaya Tenaga Malaysia.

The following document shall be referred in determining the compliance to operational conditions terms:

- a) Electricity Supply Act & Regulations
- b) The Malaysian Distribution Code

For customers connected to Distributor licensee system, connecting indirect Solar PV power generation system internally requires compliance to requirements stated in this document. Power generated from indirect Solar PV power generation system is potentially able to disrupt the existing network quality, security & safety.

Without proper consideration, connecting indirect Solar PV power generation system could result in:

- a) Voltage fluctuation
- b) Voltage rise
- c) Voltage unbalance
- d) Overloading of existing grid connecting feeder/cable
- e) Power Quality issues
- f) Islanding
- g) Coordination with other on-site generations such as backup generator, co-gen and energy storage system

1.3 Boundary of ownership and responsibilities

Boundary and responsibility limits of Distribution Licensee & NEM consumer must be clearly demarcated, agreed and documented.

Distribution Licensee responsibility is up to the metering point which is as the normal distributor customer boundary.

1.4 Approvals & license to build & operate

The consumer shall acquire the appropriate approval from relevant authorities and employ competent personnel to design the installation which include:

- Permit by local authority
- Permit by respective regulatory bodies
- Competent installer under regulation
- Competent operator
- Repair & maintenance

2.0 Scope

2.1 Scope

The main objective of this guideline is to provide guidance on the technical requirements for customers connected to the Distribution system who plan to install indirect Solar PV generation.

This guideline outlines technical requirements to ensure that connection of the indirect Solar PV power generation system would be standardised in terms of scheme, devices, operation & limits. The ultimate objective is to harmonise indirect Solar PV power generation system with the existing supply network, neighbouring customer and other Distributed Generators (DG) within the same distribution network. Connection of indirect Solar PV power generation system should not cause breach of power quality, reliability and security of the network and safety of the operators and public.

This guide covers requirements for connection of indirect Solar PV power generation system to the customer internal system. Power generation include:

- a) Indirect connection solar photovoltaic
- b) Battery Energy Storage System (BESS)

Limit of capacity for the indirect Solar PV power generation system under this guideline is up to 75% of maximum demand of consumer's current installation.

2.2 Commercial matters

Commercial matters are not part of this guideline.

2.3 Application process

Customers that intend to install indirect Solar PV power generation system are required to register with the Distributor licensee. Registration to Distributor licensee is a statutory requirement as the consumer has altered the system registered during initial application.

The application process and procedures are described in the "Guidelines For Solar Photovoltaic Installation on Net Energy Metering Scheme".

3.0 Glossary

Demand	:	The demand of MW or MVA _r of electricity (i.e. both Active Power and Reactive Power respectively) unless otherwise stated.
Direct Connection	:	Connection of Solar PV power generation system directly to the distribution system.
Indirect Connection	:	Connection of Solar PV power generation system to the consumer owned internal network.
Distribution licensee	:	The holder of a license to distribute issued by Energy Commission under Section 9 of the Electricity Supply Act 1990.
Distribution System	:	The system of electric lines with voltage levels below 66 kV, within the Area of Supply owned or operated by the Distributor licensee/Embedded Distributor licensee, for distribution of electricity from Grid Supply Points or Generating Units or other entry points to the point of delivery to Customers or other Distributor licensees and includes any electrical plant and meters owned or operated by the Distributor licensee/ Embedded Distributor licensee in connection with the distribution of electricity .
Harmonic	:	A sinusoidal component of a periodic wave or quantity having a frequency that is an integral multiple of the fundamental frequency.
Inverter	:	A machine, device, or system that changes dc power to ac power.
Islanding	:	A condition in which a portion of the utility system that contains both load and distributed resources remains energized while isolated from the remainder of the utility system.
Low Voltage	:	A voltage less than 1,000 volts or 1 kV.
Medium Voltage	:	A voltage exceeding 1 kV but not exceeding 50 kV.
Connection point	:	The point where indirect Solar PV power generation system is connected to the network.
Point of common coupling/ Interconnection	:	The point of connection between utility system and consumer.

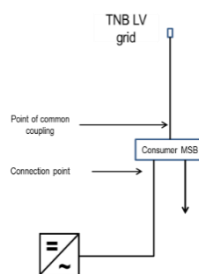

Total Harmonic Distortion (THD)	:	Harmonic distortion is the departure of a waveform from sinusoidal shape that is caused by the addition of one or more harmonics to the fundamental. Total Harmonic Distortion is the square root of the sum of the squares of all harmonics expressed as a percentage of the magnitude of the fundamental.
Type Test	:	Test of one or more devices made to a certain design to demonstrate that the design meets certain specifications.
Power Factor	:	Power factor (PF) is calculated by dividing the Real Power, P, in the W unit by the Apparent Power, S, in the VA unit.
Load profile	:	24-hour, 4 day profile (consisting of Friday to Monday) of customer electricity demand profile which include voltage, kW, kVar for 30-minute sampling
Net Energy Metering (NEM)	:	Customers with own generation whose solar PV installed capacity is for self-consumption. In the event of excess of generation, the energy is allowed to be exported to the grid.
Self-Consumption (SC)	:	Customers with own generation with installed capacity solely for self-consumption. In the event of excess of generation, the energy is not to be exported to the grid.
Peak Demand	:	Highest demand recorded in the load profile submitted during application for SG
Trough load/ Base load	:	Lowest demand recorded in the load profile submitted during application for SG
Battery Energy Storage System (BESS)	:	An energy storage system that employs battery technology for delayed applications. BESS described in this guide is used at the customer side, for the main purpose of enhanced electricity supply and integration with renewables.
Customer With Own Generation (CWOOG)	:	Term used in the MDC to categorise customers that have in-house power generation facilities that operate in parallel with the Distributor licensee distribution system. In relation to this guide, NEM consumer are those existing Distributor licensee registered customer with declared power generation facility.
Power limiting device	:	A device that is used to curtail export of excess energy to Distributor licensee's distribution system. The device could be integrated within the inverter or external.
Declared Annual Availability (DAA)	:	Annual quantity (in MWh) of renewable energy to be generated by the indirect Solar PV power generation system for each year. This information is to be furnished by NEM consumer to the Distributor licensee annually according to the agreed procedure.
Indirect Solar PV power generation	:	Power generation that utilize the solar photovoltaic technology to provide for the consumer's own demand. The indirect Solar PV power generation system is connected within the system and operate in parallel with the Distribution Licensee distribution system. Battery energy storage system could be used as part of the system.

4.0 Description of Indirect Solar PV Power Generation

- 4.1 Description** : Consumers may decide to install indirect Solar PV power generation system to reduce their import from the Distribution Licensee. The indirect Solar PV power generation system is installed within its own system. The connection scheme is described in Chapter 5 of this guideline.
- 4.2 Battery Energy Storage System (BESS)** : Use of BESS could enhance the energy utilization. BESS converter operates in bidirectional – charging and discharging. The grid-connected inverter and BESS shall comply with connection requirements as stated in IEEE 1547.
- 4.3 Inverter requirements** : Inverters to be paralleled to the Distribution Licensee’s distribution system shall comply to the following standards and references, in term of design, operation and maintenance:

	Standards/ Guide	Scope
a)	MS 1873	Connection scheme of grid connected inverter
b)	IEC 61727	Photovoltaic systems – characteristics of utility interface
c)	IEEE 1547	Standard for Interconnecting Distributed Resources with Electric Power Systems <ul style="list-style-type: none"> ▪ This standard describes the connection requirements of various Distributed Resources to the utility network.
d)	Suruhanjaya Tenaga	“Malaysian Distribution Code”, 2017
e)	TNB	“ <i>Tenaga Nasional Berhad – Technical Guidelines for Interconnection of Distributed Generator to Distribution System, 2018</i> ”
f)	Suruhanjaya Tenaga	“ <i>Guideline For Solar Photovoltaic Installation on Net Energy Metering Scheme</i> ”
g)	TNB	“ <i>Technical Guideline for Connection of Indirect Solar PV Power Generation for Net Energy Metering</i> ”
h)	TNB	“ <i>Electricity Supply Application Handbook</i> ”

Only inverters that comply with the standards above are allowed to be operating in parallel with Distribution Licensee distribution system. Type test certifications could be used as prove of compliance.

- 4.4 Power limiting capability** : The demand from the Distribution system will reduce due to own generation by NEM consumer or export of excess energy to distribution network by NEM consumer. This could disrupt the distribution system, resulting in voltage rise and reverse power flow. During such event, the inverter shall reduce its generation upon receiving command from the detection device.

5.0 Connection Scheme

- 5.1 Introduction** : The connection scheme clauses takes into the following considerations:
- Safety
 - Connection with least alteration to existing network
 - Cost
 - Compliance to regulatory requirements
- 5.2 Connection types** : The types of connection for indirect Solar PV power generation system are as follows:
- Type A – for LV customers
 - Type B – for MV/HV customers
- Assumption is made based on inverter output at low voltage level.
- 5.3 Feedings method** : The connection method of Solar PV power generation system can be categorised as:

- a) Direct Feed – Connection point at Distribution Licensee’s grid

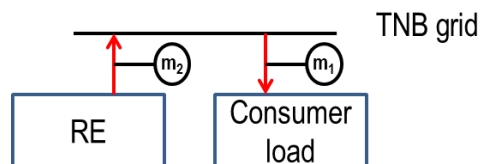

Fig. 5.1: Connection to Distributor licensee grid

Connection point is at the Distribution Licensee’s system. This method is adopted for Feed-in Tariff connections. Power consumption and power generation are segregated and measured independently by meters m_1 and m_2 respectively.

- b) Indirect Feed - Connection point at consumer

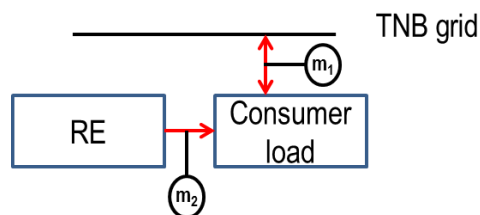

Fig. 5.1: Connection to TNB grid

Connection point is within the consumer’s network without direct connection to the Distribution Licensee’s system. This method is adopted for Net Energy Metering and Self Consumption schemes. Power consumption and export are measured by m_1 , while power generation is measured by m_2 . For net metering, meter m_1 shall have bi-directional capability to register the import and export units. Meter m_2 is a dedicated PV meter to record the generation from the indirect PV generation system and all costs relating to the PV meter shall be borne by the consumer.

**5.4 Type A:
LV customer
connections**

: Type A is applicable for Distribution Licensee's consumer with connection to LV network.
PV connection point shall be done at the consumer's DB/MSB.

Use of a single phase inverter shall not cause unbalance conditions to Distribution Licensee's system. If such a condition is violated, requirement of a three phase inverter is automatically enforced.

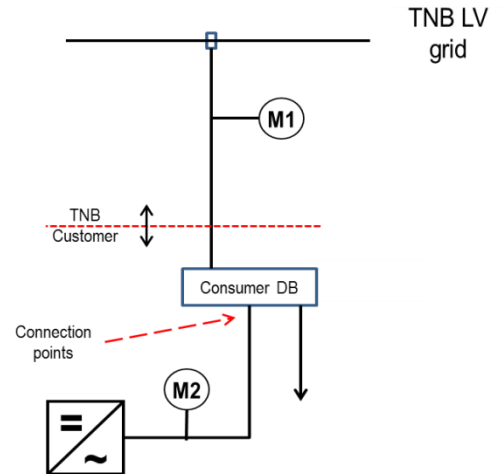

Fig. 5.3: Type A connection

Annual readings for M2 are to be furnished to Distribution Licensee.

**5.5 Type B:
MV customer
connections**

: Type B connection is applicable for Distribution Licensee's consumer with connection to MV network.
PV connection point shall be done at the consumer MSB.

Use of a single phase inverter shall not cause unbalance conditions to Distribution Licensee's system. If such a condition is violated, requirement of a three phase inverter is automatically enforced.

Accumulated annual readings for M2 and M3 are to be furnished to Distribution Licensee.

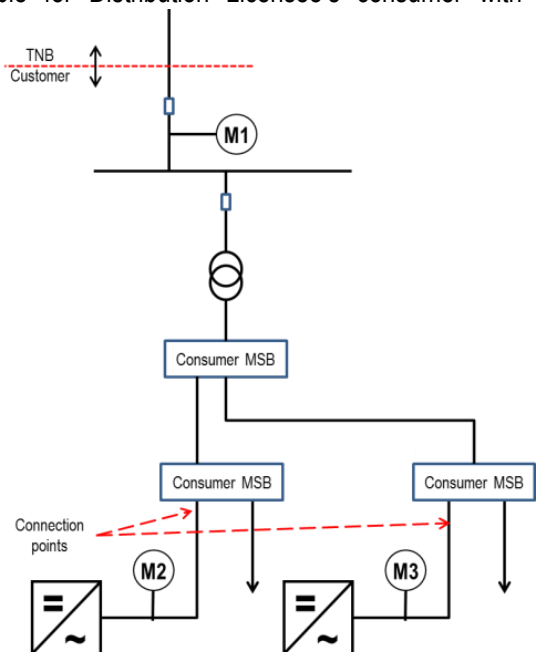

Fig. 5.4: Type B connection

6.0 General Requirements

6.1	Introduction	Connection of indirect Solar PV power generation system for NEM consumer shall be done internally which shall result in no requirement for upgrading of the existing utility supply infrastructure such as cable, fuse, switchgear, transformer and protection scheme.
6.2	Connection Requirement	<p>As a result of installation of indirect Solar PV power generation system, the quality of power at the point of connection shall not be made worse than the existing quality of supply. Quality of supply is measured as compliance to the standards on voltage, flicker, frequency, harmonics and power factor. To ensure that the addition of indirect Solar PV power generation system does not adversely impact the quality of supply, the following requirements shall be imposed and adhered by the NEM consumer.</p> <p>Deviation from these standards represents out-of-bounds condition and may require the PV system to sense the deviation and properly disconnect from Distribution Licensee system.</p> <p>Power quality parameters (harmonics and voltage) must be measured at the utility interface/point of common coupling unless stated otherwise. At PCC, the power quality requirements must comply with Malaysian Distribution Code and this Technical Guidebook.</p>
6.3	Selection of connection point	<p>Although the connection of indirect Solar PV power generation system is within the consumer's premise, the following guides shall be satisfied to ensure that the connection does not interfere with the existing power supplied by the Distribution Licensee. The following items are to be considered during design.</p> <ul style="list-style-type: none">a) Customer load during peak and troughb) Anti-islandingc) Protection systemd) Step-up transformer (if applicable)e) Interlockingf) Back-up power supply (if applicable)g) Energy storage system (if applicable)h) Sensitive load <p>During periods of low consumption (trough) and high generation from indirect Solar PV power generation system, consumer may experience reverse power flow. The NEM consumer is to ascertain that the internal network is capable of utilising all the generated energy and its protection system is able to cater for bi-directional power flow.</p>
6.4	Connected Voltage	<p>As the connection is done internally, NEM consumer shall appoint a qualified consultant to design the interconnection between indirect Solar PV power generation system and his existing plant.</p> <p>The interconnection shall comply with the standards as described in this guideline and other regulations issued by the Suruhanjaya Tenaga.</p>

6.5	Installed capacity	<p>Installed capacity of the system to be connected must be declared correctly during application. Except for NEM, other indirect Solar PV power generation system connection shall not result in export of power to the distribution system. Restriction of export is to ensure that the system voltage does not fluctuate so much during high load, low generation and low load, high generation. The installed capacity is declared in term of summation of MWp.</p> <p>The installed capacity of the indirect Solar PV power generation system shall be capped as below:</p> <ol style="list-style-type: none"> a. Domestic consumer : up to 72kWp (12kW for single phase and 72kW for 3 phase systems) b. Commercial and industrial consumer : 75% of maximum demand of the Consumer's current installation: <ol style="list-style-type: none"> (i) based on the past 1 year average of the recorded maximum demand of the consumer's installation; or (ii) the declared maximum demand for consumers with less than 1 year. <p>The peak or maximum demand is to be supported by actual 24-hour, 4-day load profile consisting of Friday to Monday. The load profile with 30-minute reading interval.</p> <p>The capacity described above is total capacity for each site.</p>
6.6	Export limiting	<p>The export of excess energy from NEM consumer during its low demand and peak power generation could cause disruption to Distribution Licensee's network. Therefore, the amount of export is to be determined by the Distribution Licensee during the application process. For the capacity below 72kW, where there will be no analysis by the DL, the consumer shall ensure that the exported power shall be less than the existing capacity of the DL and consumer's equipment. Appropriate functionality within the inverter or use of external device to be provided to mitigate such a condition.</p> <p>Except for NEM consumer, no export is allowed. Appropriate functionality within the inverter, use of external device or energy storage must be provided. Feature and location of the function or device shall be specified in the application form & relevant drawings.</p>
6.7	Boundary of ownership & operation	<p>Boundary and operational limits of Distribution Licensee & NEM consumer must be clearly demarcated, agreed and documented. The Interconnection Operation Manual (IOM) shall be prepared and endorsed by both parties prior to the operation of the indirect Solar PV power generation system. Distribution Licensee's responsibility is up to the metering point which is as the ordinary Distribution Licensee's consumer boundary.</p>
6.8	Equipment specifications	<p>Major components of the indirect Solar PV power generation system shall comply to the following standard :</p> <ol style="list-style-type: none"> a. MS 1837 b. IEC 61727 c. IEEE 1547

6.9 Normal Voltage Operating Range : The PV system injects current into utility and does not regulate voltage.

LV indirect Solar PV power generation system shall be capable of operating within the voltage range in Table 6.1.

Table 6.1: Normal operating condition at PCC (LV)

Nominal Voltage (V)	Steady state voltage limits
400	+10% and -6%
230	+10% and -6%

MV indirect Solar PV power generation system shall be capable of operating within the limits as in Table 6.2 below;

Table 6.2: Normal operating condition at PCC (MV)

Nominal Voltage (kV)	Steady state voltage limits
6.6	±5%
11	±5%
22	±5%
33	±5%

Table 6.1 and Table 6.2 are adopted from the “Malaysian Distribution Code”

6.10 Voltage fluctuation : Power generation from indirect Solar PV power generation system constantly varies due to the changing solar irradiation throughout the day. The varying power generation injected into the Distribution Licensee’s network is bound to create voltage fluctuations at the interconnection point and other buses within the grid.

The maximum voltage fluctuation range allowed for LV and MV due to varying solar radiation is 6%. Beyond this, there is a danger of utility and consumer equipment getting heated up.

An appropriate voltage control is to be undertaken to mitigate the voltage fluctuation when necessary.

6.11 Harmonic

The harmonic of a wave is a component frequency of a wave that is an integer multiple of the fundamental frequency. In the presence of non-linear loads such as computer power supplies and other appliances, alternating current (AC) can be distorted by introduction of various harmonic frequencies. Harmonics can be measured by percentage of the fundamental frequency or by calculating total harmonic distortion (THD). When present at high levels; these harmonics are detrimental to the electrical system and its loads.

The PV system output should have low current-distortion levels to ensure that no adverse effects are caused to other equipment connected to the utility system.

Total harmonic current distortion shall be less than 5 % at rated inverter output at cable connected to PCC. Each individual harmonic shall be limited to the percentages listed in Table 6.3.

Even harmonics in these ranges shall be less than 25 % of the lower odd harmonic limits listed.

Table 6.3 – Current distortion limits (IEC 61727-2003 Table 1)

Odd harmonics	Distortion limit (%)
3 – 9	< 4.0
11 – 15	< 2.0
17 – 21	< 1.5
23 – 33	< 0.6

Even harmonics	Distortion limit (%)
2 – 8	< 1.0
10 – 32	< 0.5

Note:

- *The harmonic current injection should be exclusive of any harmonic currents due to harmonic voltage distortion present in the utility grid without the PV system connected.*
- *Type tested inverters meeting the above requirements should be deemed to comply without further testing.*

6.12 Inverter Power Factor

The power factor is defined as the ratio between the applied active power and the apparent power.

PV systems shall have a leading or lagging power factor greater than 0.9 and 0.85 respectively when the output is greater than 20 % of the rated inverter output power. The smart inverters used shall automatically make necessary adjustments to ensure that the power factor does not cause voltage rise beyond the permissible limit.

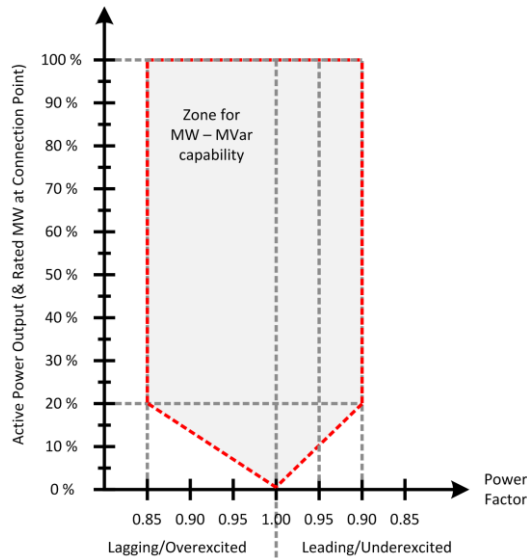

Fig. 6.1: Reactive power requirement at connection point

6.13 Reactive Power Compensation

Consumer should be aware that if the installed indirect Solar PV power generation system is set to operate at unity power factor, reactive power for their load will be totally imported from Distribution Licensee and real power will be mixed of own generation and import from Distribution Licensee.

This will result in low power factor reading at Distribution Licensee tariff meter as the ratio of reactive power to active power is higher with own generation.

Therefore, customer is advised to consult their service provider to provide internal compensation to avoid from being penalised.

6.14 DC Injection

The PV system shall not inject DC current greater than 1 % of the rated inverter output current into the utility interface under any operating condition.

6.15 Flicker

Flicker is due to rapidly changing loads that cause fluctuate in the customer's voltage. Even a small change in voltage can cause noticeable. Flicker is an irritation issue.

The operation of the PV system should not cause voltage flicker in excess of values stated in Table 6.4;

Table 6.4– Reference: TNB LV Planning Guidelines

Distribution system voltage level which the fluctuating load is connected	Absolute short term flicker severity (P _{st})	Absolute long term flicker severity (P _{lt})
LV Systems	1.0	0.8
11kV – 33kV	0.9	0.7
Above 33kV	0.8	0.6

6.16 Voltage unbalance

Voltage unbalance is defined as the ratio of the negative sequence voltage component to the positive sequence voltage component.

Negative Phase Sequence Voltage (%): 2% for 1 minute duration when multiple single-phase PV units are installed and it should be distributed evenly among the three phases of the power system.

Infrequent short duration peaks with a maximum value of 2% are permitted for Voltage Unbalance.

The unbalance voltage shall not exceed 1% for 5 occasions within any 30 minute time period at the terminals of a user's installation.

6.17 Short circuit level

By regulation, Distribution Licensee is required to ensure that short circuit level of the network is within the equipment ratings. The regulation specifies that network maximum sub-transient 3-phase symmetrical short circuit shall be within 90% of the equipment designed short-time make & break capacity. Table 6.5 highlights the typical equipment ratings in Distribution Licensee's distribution network.

Table 6.5– Typical Equipment ratings in TNB Distribution Network

Nominal Voltage [kV]	Rated Voltage [kV]	Fault Current [kA]
33	36	25
22	24	20
11	12	20
0.4	1.0	31.5

7.0 Penetration Limit

7.1 Introduction

NEM consumers are allowed to export any excess energy to TNB, provided that the exported power are within the capacity of the existing equipment (TNB and consumer) and the voltage levels are within the limit.

Generation power limiter is necessary to ensure that during periods of low load and high solar generation, the local voltage level would not rise beyond the limit and the exported power are still within the capacity of the existing equipment (TNB and consumer)

7.2 Individual penetration

a) Net Energy Metering (NEM)

Applicable for Distribution Licensee registered consumer only. Consumer should decide on the installed capacity with consideration of their own daytime peak demand. Maximum installed capacity as shown in Table 7.1.

Table 7.1– Maximum installed capacity allowed for NEM customer

Category	Maximum capacity installed	
Domestic	Single phase Three phase	12kWp 72kWp Exported power to TNB shall be less than the existing capacity of TNB and consumer's equipment
Commercial and Industry	MV Consumer LV Consumer	75% of consumer's maximum demand

However, periodically, during low household power consumption period and high solar PV generation, the excess power is to flow into the grid.

b) Self-Consumption

Self-consumption means that the generated power is fully consumed within the customer premise. No export is allowed, therefore self-consumption consumer shall install a device that will prevent the export. The export curtailment is to prevent any voltage rise at the point where the indirect Solar PV power generation system is connected to the consumer MSB.

Limit for installed capacity is similar to that of NEM which refer to table 7.1 above.

c) BESS

Installed capacity of BESS should not cause any export to Distribution Licensee's grid. Appropriate limiting device must be emplaced.

8.0 Protection Guidelines

- 8.1 Introduction** : Protection system for indirect Solar PV power generation system is to be designed to isolate the faulty from the healthy sections of the system.

DG protection scheme is under NEM consumer responsibility and NEM consumer is to declare the protection scheme and settings to Distribution Licensee. NEM consumer shall design a protection system that fits his target degree of system security. Nonetheless, NEM consumer shall comply to Distribution Licensee's protection requirements to ensure that the fault would not spread beyond the plant.

NEM consumer is to perform protection coordination study to determine the suitable settings to protect the system during fault. Results of such study are to be furnished to Distribution Licensee for reference. Distribution Licensee shall advise NEM consumer on the appropriate settings at the point of common coupling.

For NEM consumer interconnection feeder protection scheme shall inhibit unsafe synchronization.

- 8.2 Smart inverter** : Connection of power generation to distribution network could cause voltage rise during low load, high generation condition. Also, sudden loss of generation from DG\ could cause instability of the network, especially for system with high DG penetration.

Advanced inverters or known as smart inverters are capable of providing additional features in addition to the power conversion. Smart inverters are PV inverters that stay connected and provide additional functions to help actively support the grid - mainly voltage and frequency. Traditional inverters simply disconnected when the grid voltage or frequency went out of range. Broadly, smart inverters provide some additional benefit to the grid beyond simply converting direct-current (DC) electricity to alternating current (AC) from PV systems. The smart inverter functions is outlined in the Attachment A.

- 8.3 Frequency** : Distribution Licensee shall maintain the system frequency and the PV system shall operate in synchronism with Distribution Licensee's frequency. Distribution Licensee shall operate with nominal 50 Hz system with $\pm 1\%$ range band.

- 8.4 Synchronisation** : Synchronisation is an act of matching, within allowable limits, the required DG parameters with the Distribution Licensee’s utility supply parameters as in Table 8.1.

Table 8.1– Parameters required for synchronisation

Parameters	Required range
a. Frequency difference	<0.2 Hz
b. Voltage magnitude difference	< 10%
c. Voltage angle difference	< 10 deg
d. Interlocking logic are satisfied	-

Synchronisation is to be done at the inverter. Re-synchronising is only to proceed once Distribution Licensee’s system is normalized and stabilized as in Table 8.2.

Table 8.2– Time taken for re-synchronising

Voltage	Time
LV	2 minute
MV	5 minute

- 8.5 Anti-islanding inverter** : Non islanding inverters are unable to supply the load without the presence of the Distribution Licensee’s system. For personnel safety reasons, PV plant is not allowed to be energized during outage of Distribution Licensee grid (loss of mains). The NEM consumer shall disconnect from the Distribution Licensee’s system for loss of main within 2 second.

Inverters used by NEM consumer shall provide the following anti-islanding detection techniques:

- a) Under Voltage
- b) Over Voltage
- c) Under Frequency
- d) Over Frequency
- e) 1 additional anti-islanding technique

NEM consumer is to prove the anti-islanding capability of the plant during commissioning tests.

- 8.6 Inverter Fault Detection** : PV system with inverter shall use abnormal voltage or frequency sensing for fault detection.

- 8.7 Inverter fault current contribution** : The fault current contribution by the inverter will be limited usually by inverter control. Based on IEEE 1547, the typical range of short circuit current is between 100% and 200% of the rated inverter current. NEM consumer shall ensure that inverters used comply to the IEEE1547 requirement.

- 8.8 Protection schemes** : The basic requirements for the design of the protection schemes shall be as follows:
- a) For any internal fault in the indirect Solar PV power generation system, the indirect Solar PV power generation system must not cause problems to the Distributor licensee system and its customers.
 - b) For any distribution network fault outside the indirect Solar PV power generation system plant, the PV system must be protected from any damaging effect.

NEM consumer shall be required to provide other protection devices to complement existing special features.

- 8.9 Failure of indirect Solar PV power generation system protection or control equipment** : Indirect Solar PV power generation plant must be disconnected from the distribution system during any of the system failure. Failure condition of indirect Solar PV power generation system equipment shall include:
- a) Failure of protection equipment
 - b) Failure of control equipment
 - c) Loss of control power

- 8.10 Voltage disturbance** : The inverter should sense abnormal voltage and respond according to the conditions in Table 8.3. Consideration shall be given to monitoring voltage in this clause in order to avoid problems due to voltage drop in various transformer, wiring or feeder circuit. When the inverter sense the voltage lies outside its operating limits, the recommended action shall be as in Table below.

Table 8.3– Voltage Disturbance

Voltage (at PCC)	Maximum trip time (s)
$V < 50\%$	0.10
$50\% \leq V < 90\%$	2.00
$90\% \leq V \leq 110\%$	Continuous operation
$110\% < V < 135\%$	2.00

Inverters are expected to continuously operate during distribution network voltage fluctuation $\pm 10\%$ of its nominal.

During the time of voltage disturbances which could be the result of transmission network switching and distribution switching on nearby feeder, the voltage would be affected. Therefore, inverters must be able to ride thru the voltage disturbance bands of 50% to 90% and 110% to 135%. This is to help stabilise the Distribution Licensee's system.

Loss-of-mains is indicated by voltage drop less than 50%.

Over voltage and under voltage detection shall be provided for all 3 phases.

- 8.11 Frequency disturbance** : The under frequency and over frequency levels and the corresponding inverter trip time shall be as follows:
- a) When the utility frequency is outside the nominal 50 Hz value by $\pm 1\%$.
 - b) Trip time shall be within 0.20 s.
 - c) Applicable for both LV and MV interconnection.

- 8.12 Utility interface disconnect switch** : Indirect Solar PV power generation system interconnection must incorporate utility interface disconnect switch to allow disconnection of indirect Solar PV power generation system output from the interconnecting with Distribution Licensee for safe utility line works. The requirement of such switch could be referred to MS 1837. The switch shall be manual, lockable, load break disconnect switch that:
- a) Provide clear indication of switch position
 - b) Visible and accessible to maintenance and operational personnel
 - c) Provide visual verification of the switch contact position when the switch is in open position

- 8.13 SCADA** : The provision of SCADA together with RTU cubicle, associated cards and SCADA ready switchgear is mandatory for all DG plant interconnection of 1MW and above. SCADA equipment to be used is subject to the approval by Distribution Licensee.

The following parameters are to be made available for monitoring by the Distribution Licensee Control Centre:

- a) Frequency (Hz)
- b) Voltage (V)
- c) Current (A)
- d) Real Power Energy Flow (kW or MW)
- e) Reactive Power Energy Flow (kVAR or MVar)
- f) Circuit Breaker Status
- g) Relay indications

All interfacing wiring to be prepared by DG developer with Distribution Licensee supervision.

9.0 Metering

9.1 Introduction

Existing single phase and three phase whole current meter needs to be replaced to a bi-directional supply meter. The meter for large power consumer shall be replaced only if bi-directional register is required.

The existing meter board and its wiring (if required) to be re-located or to be replaced by the registered wireman appointed by the consumer. The location of the meter shall be assessable to TNB personnel, facing the main entrance and comply with the latest Electricity Supply Application Handbook.

The consumer shall bear all costs associated with the connection of indirect Solar PV power generation system including costs of meter replacement, supply upgrading, and system connection/modification (if applicable).

9.2 Energy meters

Energy meters are required to measure:

- a. The monthly Distribution Licensee-NEM consumer import & export (M1) for the purpose of net energy calculation. The M1 meter will be installed by TNB.
- b. The generation output energy from the indirect Solar PV power generation system (M2, M3). The M2/M3 meters will be installed by the consumer.

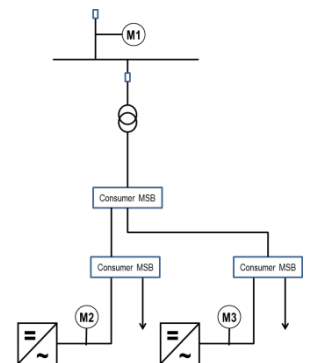

Fig. 9.1: Location of Energy Meters

9.3 Communication signal

Distribution Licensee uses wireless mode of communication between energy meter and HQ. Location of the meter room shall have adequate reception of the wireless signal to enable data transmission. NEM consumer shall provide a signal booster device whenever the communication signal is weak.

10.0 Safety Requirements

- 10.1 Introduction** The installation of grid-connected indirect Solar PV power generation systems shall comply with the requirements of MS IEC 60364 or MS IEC 60364-7-712. The provisions of this section are aimed at ensuring that these requirements are met, taking into account a range of system topologies and earthing arrangements.
- 10.2 Operation** It is important that for the safety of operating staff and public, both the Distribution Licensee and the NEM consumer operator must coordinate, establish and maintain the necessary isolation and earthing when work and/or tests are to be carried out at the interface/connection point.
- The safety coordination applies to when work and/or tests that are to be carried out involving the interface between the distribution network and the indirect Solar PV power generation system plant and it is the responsibility of the Distributor licensee and NEM consumer operator to comply with the requirements of statutory acts, regulations, sub – regulations, individual license conditions, Standardized Distributor licensee’s Safety Rules and the Malaysian Grid Code.
- 10.3 Interconnection Operation Manual** Interconnection Operation Manual (IOM) is to be prepared by the NEM consumer for indirect Solar PV power generation system >425kW.
- 10.4 Labelling** Labels shall be clearly placed to remind the operator that the device should be access cautiously as there could be an energised part that comes from the indirect Solar PV power generation system.

Test before touch must be practiced.



11.0 Application Process

11.1 Introduction

All indirect Solar PV power generations system with generation capacity of above 72kWp shall perform technical assessment with Distribution Licensee prior to NEM application to Implementing Agency.

The purposes of the assessment are for the following benefits:

- assist NEM applicant to decide on the feasibility of the project in terms of cost
- determine technical requirements needed for interconnection
- safety

NEM consumer is required to submit an application to Distribution Licensee office at:

Level 16, Wisma TNB Jalan Timur,
46200 Petaling Jaya,
Selangor

11.2 Technical information

The following technical information is required to make assessment of the proposal.

	NEM >72kW	BESS
Project information		
Applicant identity	✓	✓
Information of project	✓	✓
Design		
SLD ¹	✓	✓
Installed capacity	✓	✓
Declared Annual Availability	✓	✓
Expected commissioning	✓	✓
Equipment datasheet		
Inverter/converter datasheet	✓	✓
Battery datasheet	✓ ²	✓
Wind turbine datasheet	x	x
Prove of anti-islanding compliance	✓	✓
Power limiting device datasheet	✓	✓ ³
Penetration assessment		
Customer 4-day load profile consisting of Friday to Monday	✓	✓
Profile of Distributor licensee import-indirect Solar PV power generation system demand mix	✓	✓
Confirmation of zero export / limit (if required)	✓	✓
Other approvals		
Local authority	✓	✓
Structure	x	x

¹ SLD shall be endorsed by the Professional Engineer and qualified system designer

² Required if BESS is made part of the system

³Exception could be considered if this feature is incorporated within battery management system

11.3 NEM Assessment Study (NEMAS) – for capacity above 72kW

The assessment conducted will be based on the Consumer’s load profile which shall include, but are not limited to:

- (i) general description of the electrical supply system and connection of solar PV system;
- (ii) network study from Consumer side to the Point of Common Coupling;
- (iii) analysis on voltage and power factor impact to Distribution Licensee network;
- (iv) for capacity above 425kW, fault analysis will be conducted; and
- (v) any other analysis required by the Distribution Licensee for the purpose of safety and security of the distribution network and other electricity consumer.

11.3 NEM Self-Assessment Study (for capacity below 72kW)

During application, self-assessment is required to determine the suitable capacity and connection requirements. Self-assessment study is to be done by the qualified personnel.

Contents of the study include:

- Adequacy – to ensure no export above the limit of equipment capacity
- Voltage rise
- Recommendation

12.0 Testing & commissioning

- 12.1 Introduction** : There are 2 types of testing required:
- a) Inverter compliance tests
 - b) Interconnection compliance tests

Inverter compliance test

NEM consumer is responsible to ensure that the inverter unit(s) are in compliance to the requirements of this guideline.

Certified results of tests must be submitted for verification.

Interconnection compliance tests

Prior to commissioning, the interconnection must be tested to ensure that the performance is up to the required standard, installations are according to the approved scheme, settings are done as approved, etc.

Connection of indirect Solar PV power generation system plant should not have detrimental impact to the operation of Distribution Licensee's grid.

Tests to prove the following items shall be carried out in the commissioning process:

- a) Anti-islanding on loss of mains,
- b) Interlocking scheme (if any)
- c) Equipment functional tests
- d) Power Quality measurement

- 12.2 Commissioning tests** Commissioning tests of the installation shall be carried out by the competent person appointed by NEM consumer.

All tests must be carried out by qualified testers.

Test equipment must have valid calibration certificate.

- 12.3 Commissioning of LV connection** For connections that are situated on a long feeder, special attention to the voltage level during peak and low load is to be made. Such a condition could result in excessive voltage rise during low load period.

13.0 Operation and Maintenance

- 13.1 Introduction** NEM solar PV installation is owned and maintained by the Consumer.
- 13.2 Boundary** Any failure of supply from TNB grid including the bidirectional meter shall be rectified and normalized by TNB.
- Any failure of the consumer's electrical installation (after TNB meter) and solar PV system shall be rectified and normalized by the Consumer.
- In the event of TNB supply failure, the Consumer has to ensure that there shall not be any reverse power/back feed from any internal source of generation (example solar PV, battery, generator) to TNB grid.
- The Consumer is solely responsible for any accident/incident to human beings and equipment that may occur due to reverse power/back feed from any internal source of generation when the TNB grid supply is off.
- TNB reserves the right to disconnect TNB supply to Consumer at any time in the event of default as specified in the NEM contract, damage to its grid, meter, etc, or to prevent accident or damage.

14.0 Other Requirements

14.1 Introduction : In addition to the technical requirements described in the previous sections, the following administrative requirements must be fulfilled.

Local authorities

- a. *Kebenaran Merancang* from the local authorities for overall plant.
- b. Building plan approval
- c. Site suitability

Regulator

- a. Generating license for capacity greater than 72kW from Suruhanjaya Tenaga
- b. Registration with authority for less than 72kW.

Land owner

- a. For tenants, written approval by the land owner shall be obtained.

The above list is not exhaustive.

ATTACHMENT A : Smart Inverter Functions

- Continued growth of PV generation puts more challenges on grid infrastructure designed for distribution from centralized energy sources. Advanced or smart inverter functions can help address the grid stability problems posed by high levels of variable distributed generation
- Smart inverters are PV inverters that stay connected and provide additional functions to help actively support the grid - mainly voltage and frequency. Smart Inverters able to receive commands from grid operators and report information. Traditional inverters simply disconnected when the grid voltage or frequency went out of range.
- Broadly, smart inverters provide some additional benefit to the grid beyond simply converting direct-current (DC) electricity to alternating current (AC) from PV systems. They typically support overall grid reliability by offering the following functions:

No.	Functions	Description	Setting	Reference
1	Anti-islanding Protection	<p>Automatically disconnect during grid failure within certain duration. The duration is adjustable.</p> <p>Anti-islanding protection is to ensure inverter doesn't back-feed a disabled grid</p>	<p>LV :</p> <ul style="list-style-type: none"> Disconnect 2sec Reconnect 2min <p>MV:</p> <ul style="list-style-type: none"> Disconnect 2sec Reconnect 5min 	<ul style="list-style-type: none"> Distribution Code: 7.8.3.5 - Protection and Control Requirements
2	Voltage and Frequency Ride-through Capability	<p>Inverter must meet the mandatory and permissive operation requirements as well as the must trip limits when the AC grid voltage and frequency high or low limits are exceeded.</p> <p>Inverters support the grid during brief voltage or frequency excursions. This function will help the grid to self-heal from a disturbance.</p> <p>During periods of (sometimes extreme) deviations in grid voltage and/or frequency, smart inverters are designed to remain connected to the grid and adjust their output to act as a counterbalance to frequency or voltage changes</p>	<p>LVRT/HVRT: Refer graph</p> <p>LFRT/HFRT: uninterrupted range 47Hz to 50.5Hz</p>	<ul style="list-style-type: none"> Distribution Code: 6.5.5.1 - Low Voltage Ride Through & 6.5.5.2 - Frequency disturbance
3	Ramp Rate Control	<p>The rate of power increase when first ramping (start ramp) and subsequent increases in offsetting or selling (normal ramp)</p> <p>To help smooth transitions from one output level to the next. Supports grid by ramping up slowly giving the grid time to adjust to the PV energy coming back online.</p>	<p>Does not exceed 15% of rated capacity per minute.</p> <p>Applicable for capacity of 5MW and above</p>	<ul style="list-style-type: none"> Grid Code: CC6.4.12

4.	Reactive Power Control Functions	<p>Inverter is able to supply or absorb reactive power to/from the grid to maintain stable grid voltage when fluctuations are prevalent.</p> <p>Variable Power Factor provides active voltage stabilization:</p> <ul style="list-style-type: none"> • Grid voltage nominal, purely active power • Grid voltage high, add 'inductive' reactive power • Grid voltage low, add 'capacitive' reactive power <p>Adjusting VARs keeps grid voltage from oscillating; acts like a shock absorber</p> <p>The reactive power control can be achieved using 3 main controls:</p> <ol style="list-style-type: none"> (a) Dynamic Volt/VAr Mode (voltage control) (b) Fixed power factor (pf control) (c) Fixed reactive power (eg: using switched reactor or capacitor) 	<p>Voltage range:</p> <p>(MV-11kV&33kV) ± 5%</p> <p>(LV- 230V & 400V) -6% +10%</p> <p>Power Factor range: 0.85 lagging to 0.9 leading</p>	<ul style="list-style-type: none"> • Distribution Code: 5.4.4.1 - Voltage range, 6.5.5.5 - Reactive power, 7.8.3.8 - Power factor
5.	Active Power Control Functions Frequency-Watt (Droop Curve) and Volt-Watt	<p>Support grid frequency and voltage by changing inverter wattage output:</p> <p>Help to stable the grid during an under/over frequency and voltage event by controlling the real output of the solar system.</p> <ul style="list-style-type: none"> • Grid frequency/voltage nominal, inverter at max output • Grid frequency/voltage high, inverter curtails power • Grid frequency/voltage low, inverter increases power 	<p>Frequency range: 47Hz to 50.5Hz</p> <p>Voltage range: (MV-11kV&33kV) ± 5%</p> <p>(LV- 230V & 400V) -6% +10%</p>	<ul style="list-style-type: none"> • Distribution Code: 6.5.5.4 - Droop curve, 5.4.41 - Voltage range & 6.5.5.3 - Power output management
6.	Data log/Memory card for event logs	<p>Capture profile of networks parameters – Voltage, Current, Frequency, Power (active & reactive), power factors and events log.</p> <p>The data log can be used for troubleshooting and monitoring purposes.</p>	N/A	Distribution Code: 6.8.1.3 - Distribution System Control Structure
7.	Remote monitoring and configurability	Able to control remotely using SCADA system (for capacity 1MW and above)	N/A	Distribution Code: 6.8.1.3 - Distribution System Control Structure